

NOTES: UNLESS OTHERWISE SPECIFIED

1. SEE DRAWING NO. CB-00292 AND PROCEDURE P-1000 FOR ASSEMBLY AND TEST INSTRUCTION. PROCEDURES AND ASSEMBLY DRAWINGS ARE FOR INTERNAL USE ONLY.
2. ALL TESTING IS PERFORMED IAW BATTERY COUNCIL INTERNATIONAL STANDARDS.
3. ALL DIMENSIONS ARE IN INCHES [MM].

REVISIONS			
REV	DESCRIPTION	DATE	APPROVED

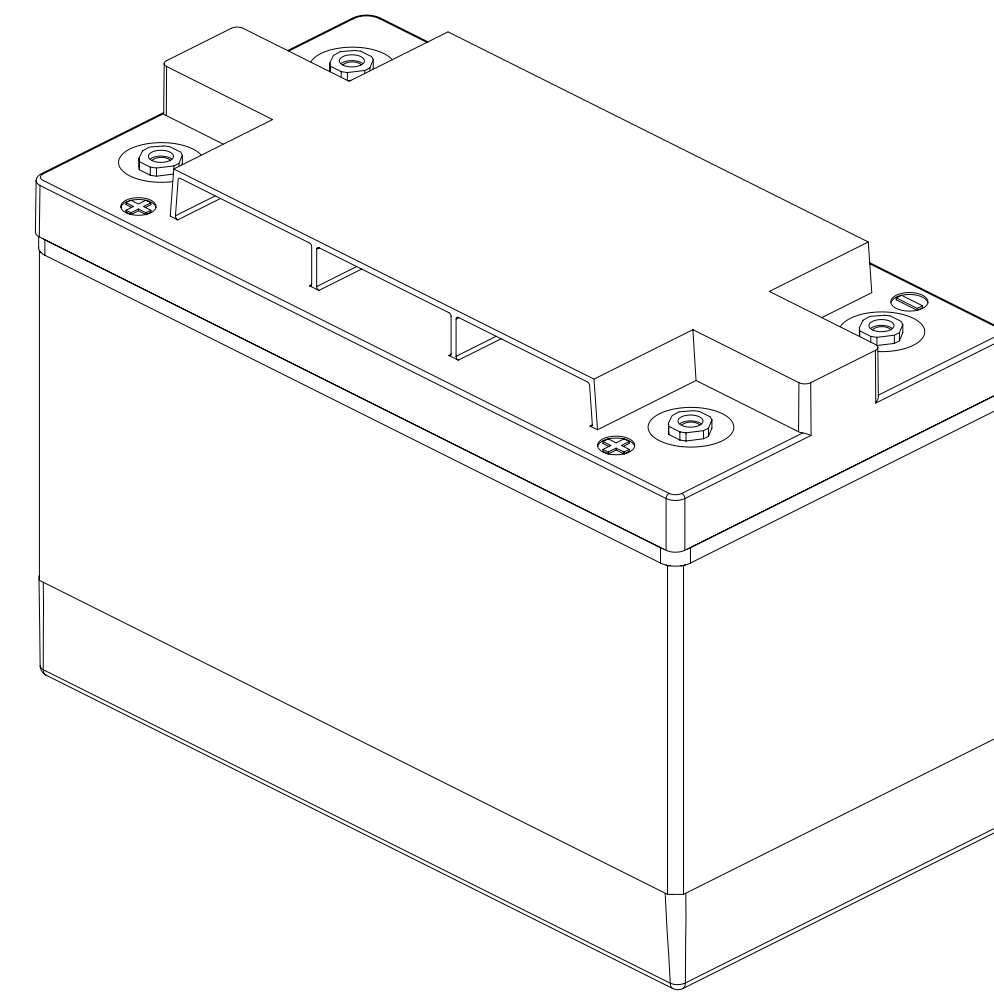
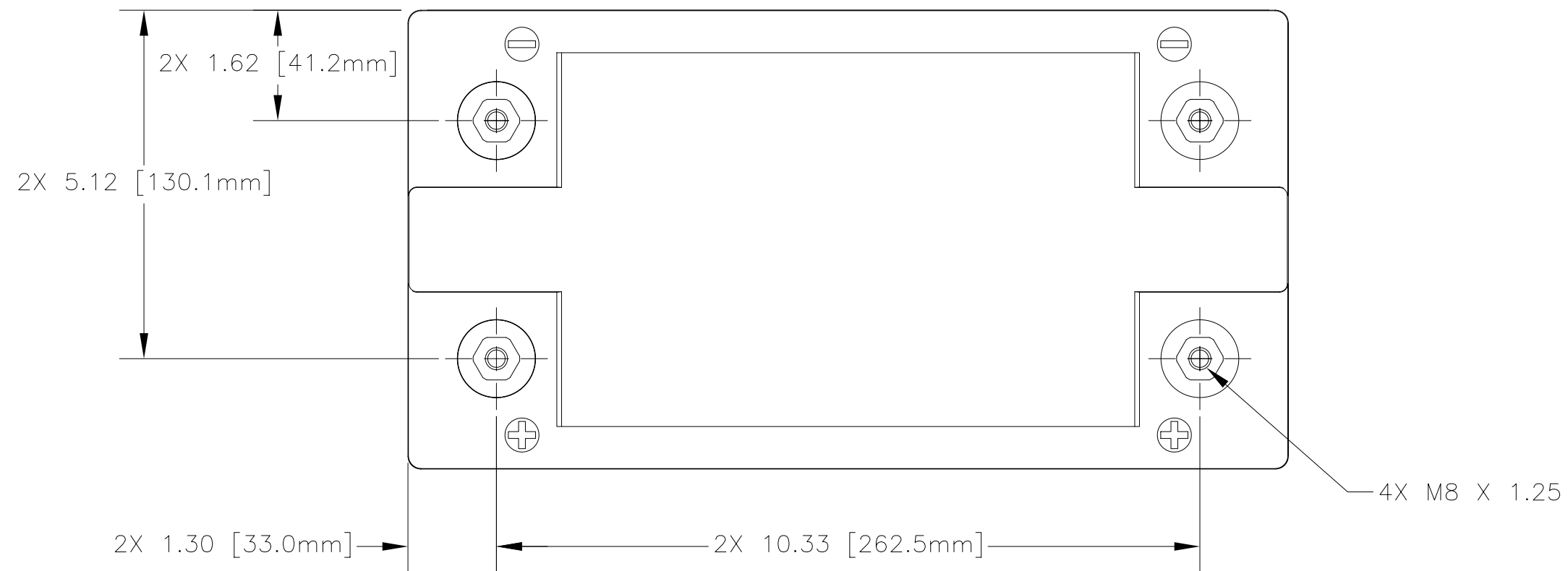

REFERENCE VIEW

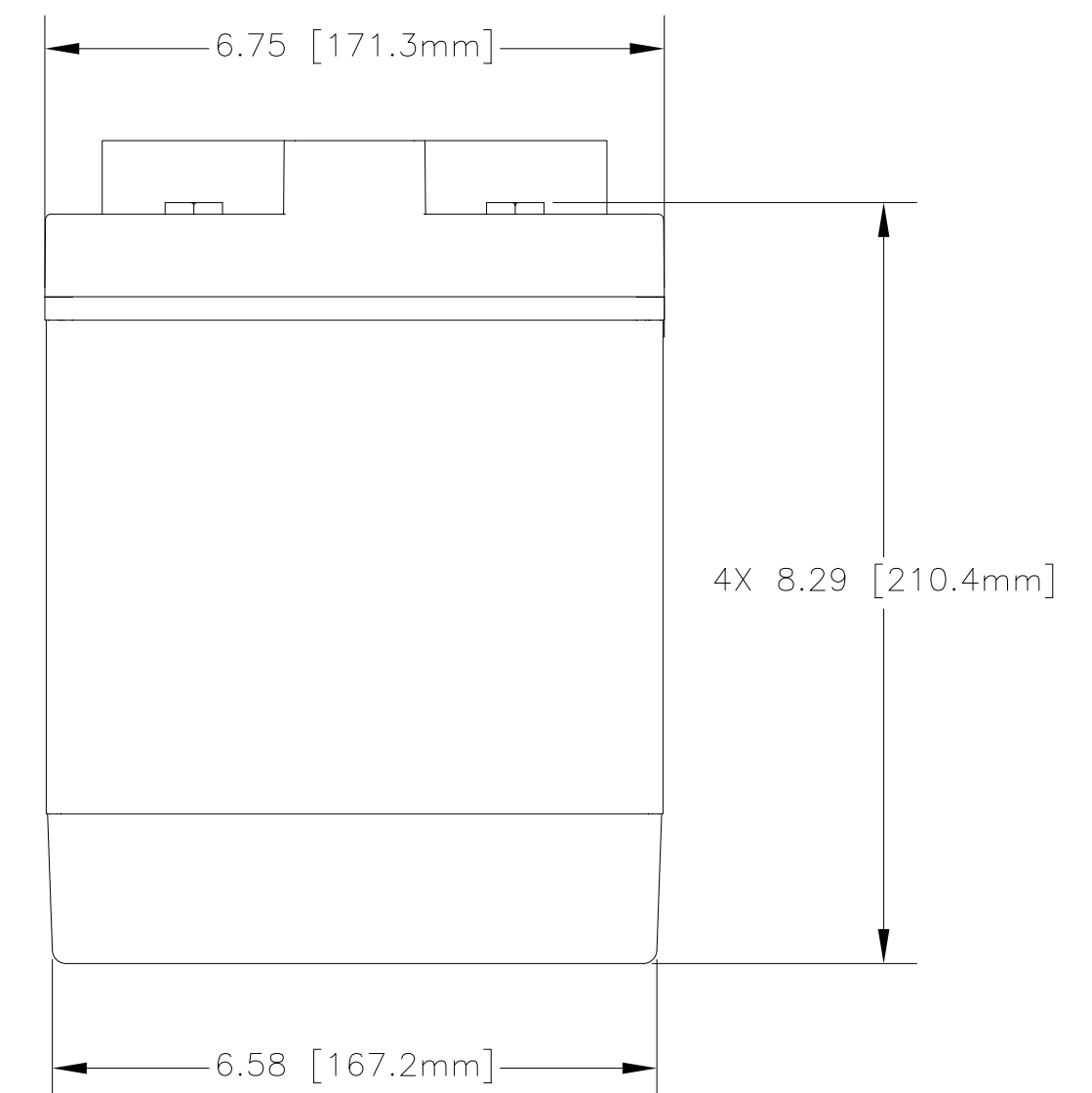
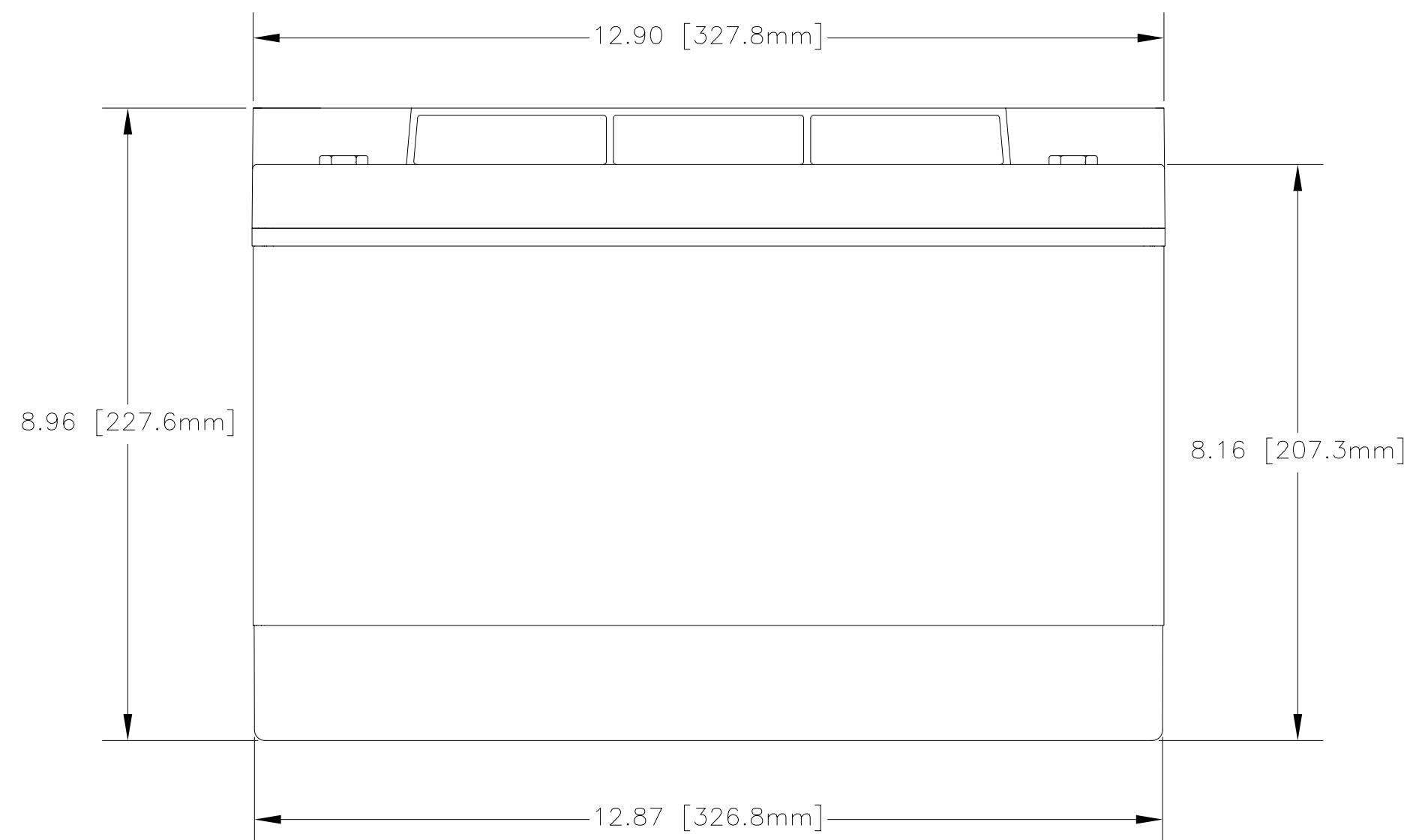

ENVELOPE DRAWING

CAPACITY RATINGS	
PART NUMBER	GPL-31T-2V
NOMINAL WEIGHT	70 LBS [31.8 KG]
AMPERE HOUR CAPACITY @ 20 HOUR 1.75 VOLTS/CELL @ 77°F (25°C)	630 AH
MINUTES OF DICHARGE @ 25 AMPS 1.75 VOLTS/CELL @ 77°F (25°C)	1170 MIN

QTY REQD	CAGE CODE	PART OR IDENTIFYING NO.	NOMENCLATURE OR DESCRIPTION	MATERIAL SPECIFICATION	ITEM NO.
PARTS LIST					
UNLESS OTHERWISE SPECIFIED DIMENSIONS ARE IN INCHES TOLERANCES ARE:			CONCORDE BATTERY CORPORATION 2009 SAN BERNARDINO RD, W. COVINA, CA 91790		
FRACTIONS	DECIMALS	ANGLES	APPROVALS	DATE	TITLE
± 1/32	.XX ± .06	± 1°	DRAWN A. MISTRETTA	1/24/08	BATTERY, 2 VOLT, GPL-31T-2V
	.XXX ± .030		CHECKED AMIII	1/25/08	SIZE CAGE CODE C 63017
TREATMENT	NONE	FINISH	APPROVED JBT	1/25/08	DWG NO. GPL-31T-2V
SIMILAR TO NA	ACT WT NA	CALC WT NA	ISSUED NS	1/25/08	SCALE NONE
				SHEET 1 OF 1	REV