

NOTES: UNLESS OTHERWISE SPECIFIED

1. SEE DRAWING NO. CB-00294 AND PROCEDURE P-1000 FOR ASSEMBLY AND TEST INSTRUCTION. PROCEDURES AND ASSEMBLY DRAWINGS ARE FOR INTERNAL USE ONLY.
2. ALL TESTING ARE IAW BATTERY COUNCIL INTERNATIONAL STANDARDS.
3. ALL DIMENSIONS ARE IN INCHES [MM].

REVISIONS			
REV	DESCRIPTION	DATE	APPROVED
F	REDESIGNED CASE AND COVER	1/22/03	JBT

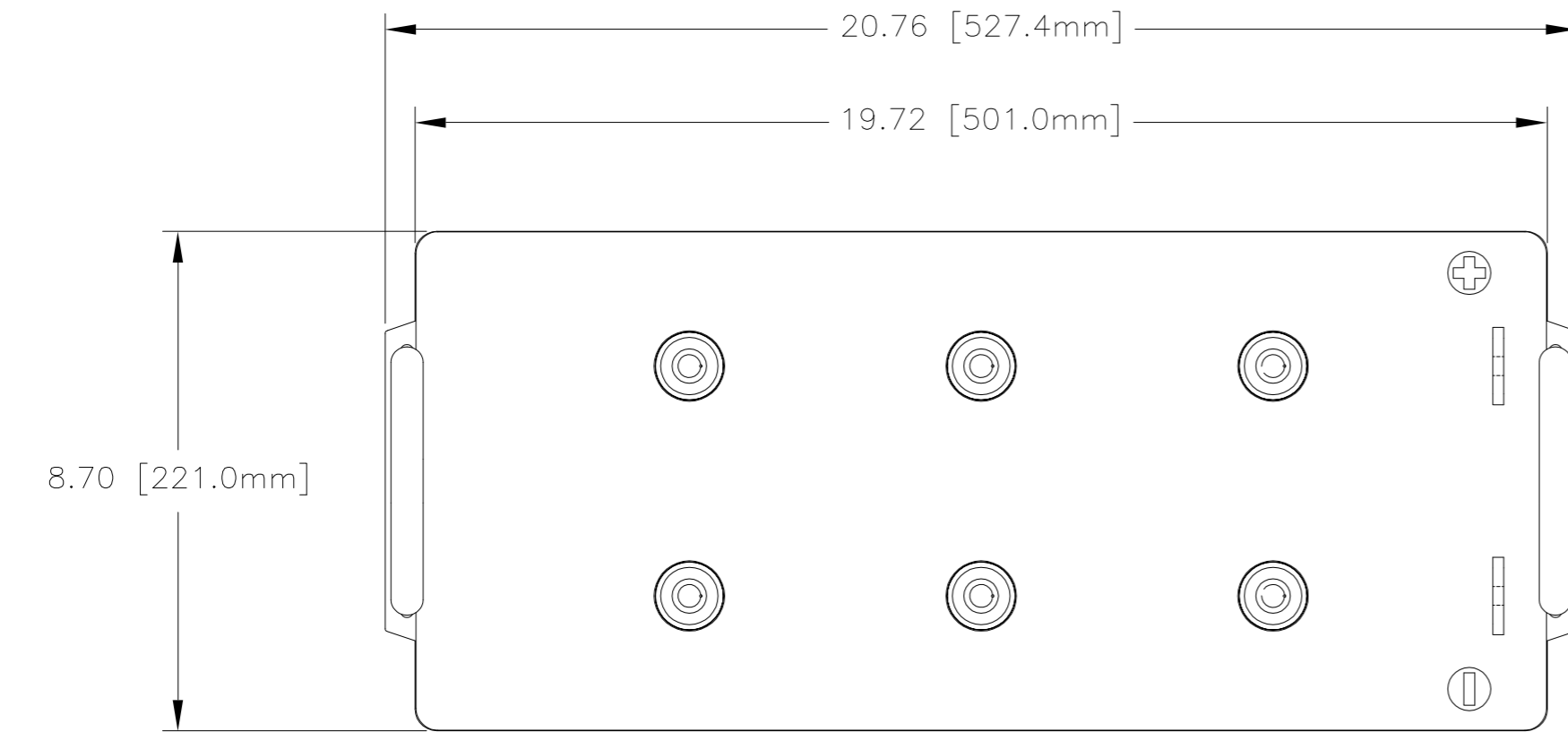

GPL-4D TERMINAL OPTIONS

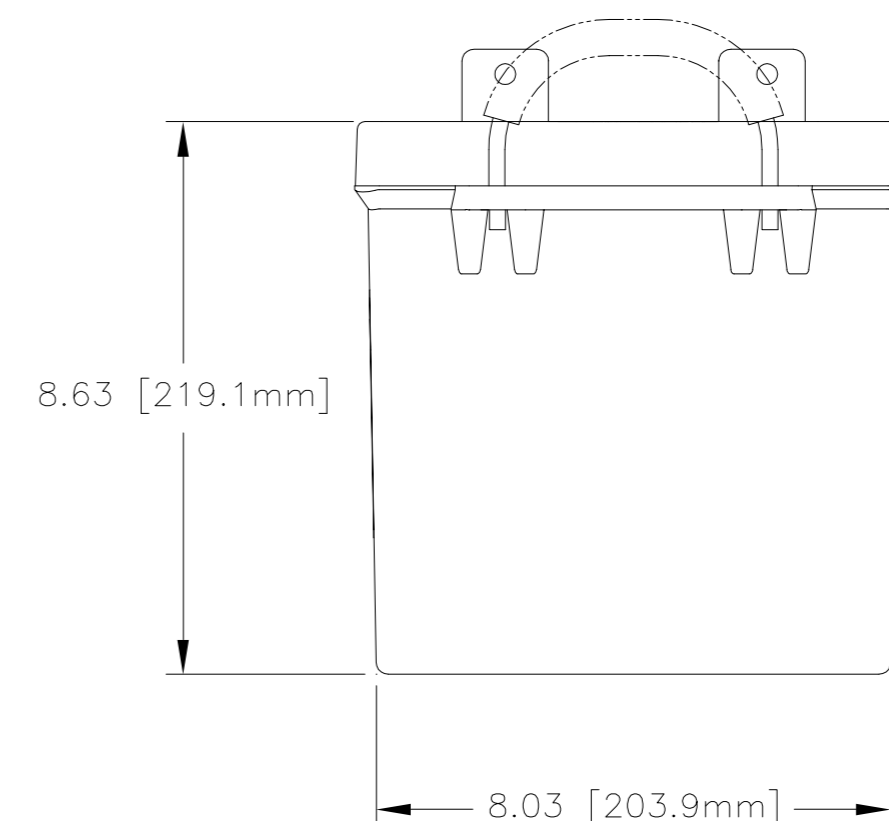
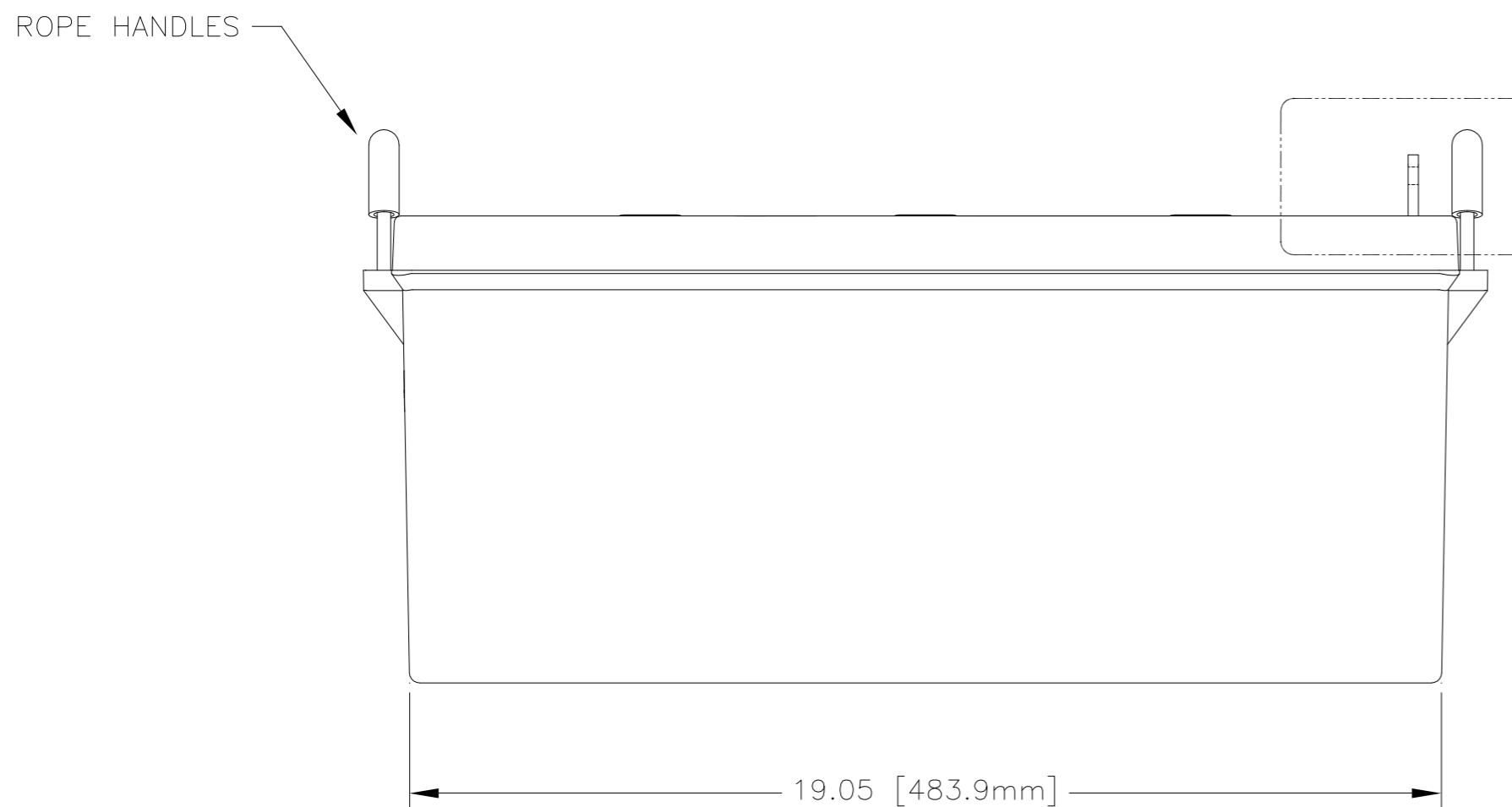
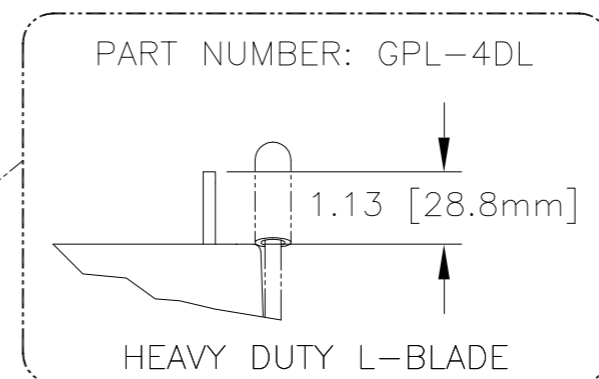
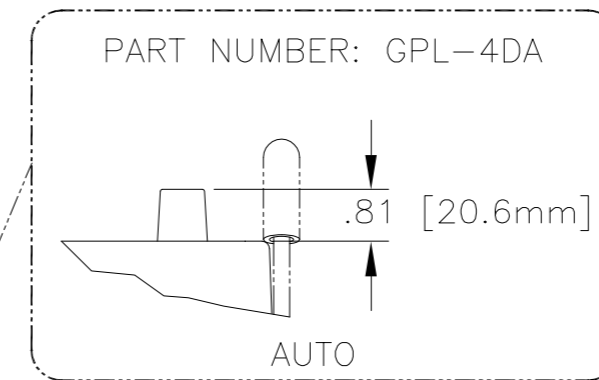

CAPACITY RATINGS	
PART NUMBER	GPL-4D
NOMINAL WEIGHT	135 LBS[61.2 KG]
AMPERE HOUR CAPACITY @ 20 HOUR 1.75 VOLTS/CELL @ 77°F (25° C)	210 AH
MINUTES OF DISCHARGE @ 25 AMPS 1.75 VOLTS/CELL @ 77°F (25° C)	390 MIN

ENVELOPE DRAWING

QTY REQD	CAGE CODE	PART OR IDENTIFYING NO.	NOMENCLATURE OR DESCRIPTION	MATERIAL SPECIFICATION	ITEM NO.
PARTS LIST					
UNLESS OTHERWISE SPECIFIED DIMENSIONS ARE IN INCHES TOLERANCES ARE:			CONCORDE BATTERY CORPORATION 2009 SAN BERNARDINO RD, W. COVINA, CA 91790		
FRACTIONS DECIMALS ANGLES ± 1/32 .XX ± .06 ± 1'			APPROVALS DATE		TITLE
			DRAWN TORRES J. 4/25/94		BATTERY, 12 VOLT, GPL-4D
TREATMENT NONE			CHECKED JR 4/29/94		SIZE CAGE CODE DWG NO. REV
FINISH NONE			APPROVED DG 4/29/94		C 63017 GPL-4D F
SIMILAR TO N/A			ISSUED AT 1/24/03		SCALE 1=2.5 SHEET 1 OF 1

ENGINEERING COPY 24JAN03