

NOTES: UNLESS OTHERWISE SPECIFIED

1. SEE DRAWING NO. CB-00295 AND PROCEDURE P-1000 FOR ASSEMBLY AND TEST INSTRUCTION. PROCEDURES AND ASSEMBLY DRAWINGS ARE FOR INTERNAL USE ONLY.
2. ALL TESTING IS PERFORMED IAW BATTERY COUNCIL INTERNATIONAL STANDARDS.
3. ALL DIMENSIONS ARE IN INCHES [MM].

REVISIONS			
REV	DESCRIPTION	DATE	APPROVED
J	550 MIN WAS 475 MIN, UPDATED HANDLES	10/7/09	DV

GPL-8D TERMINAL OPTIONS

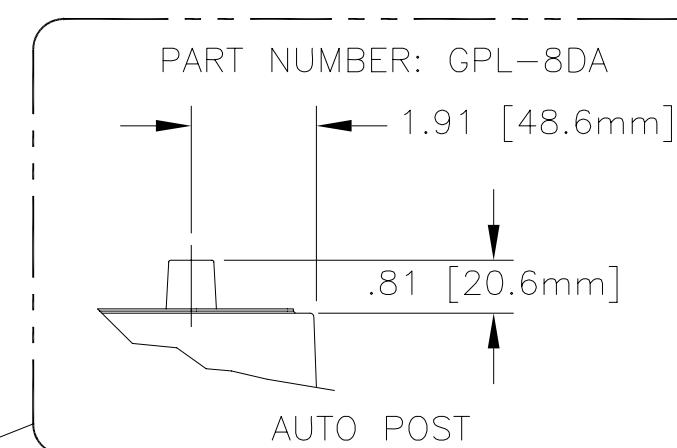
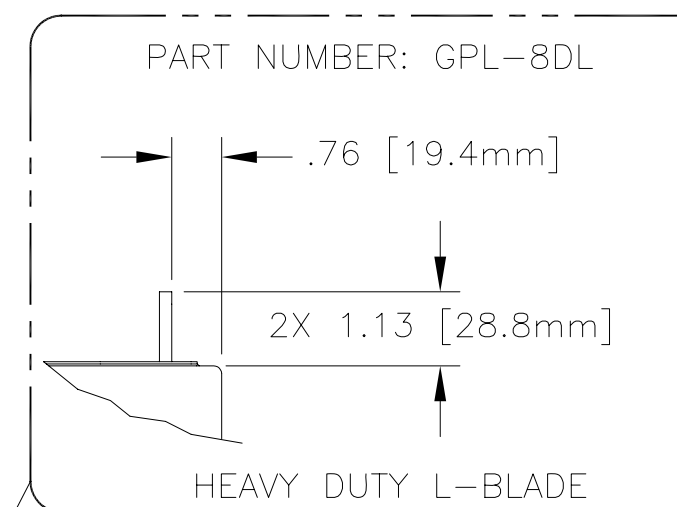
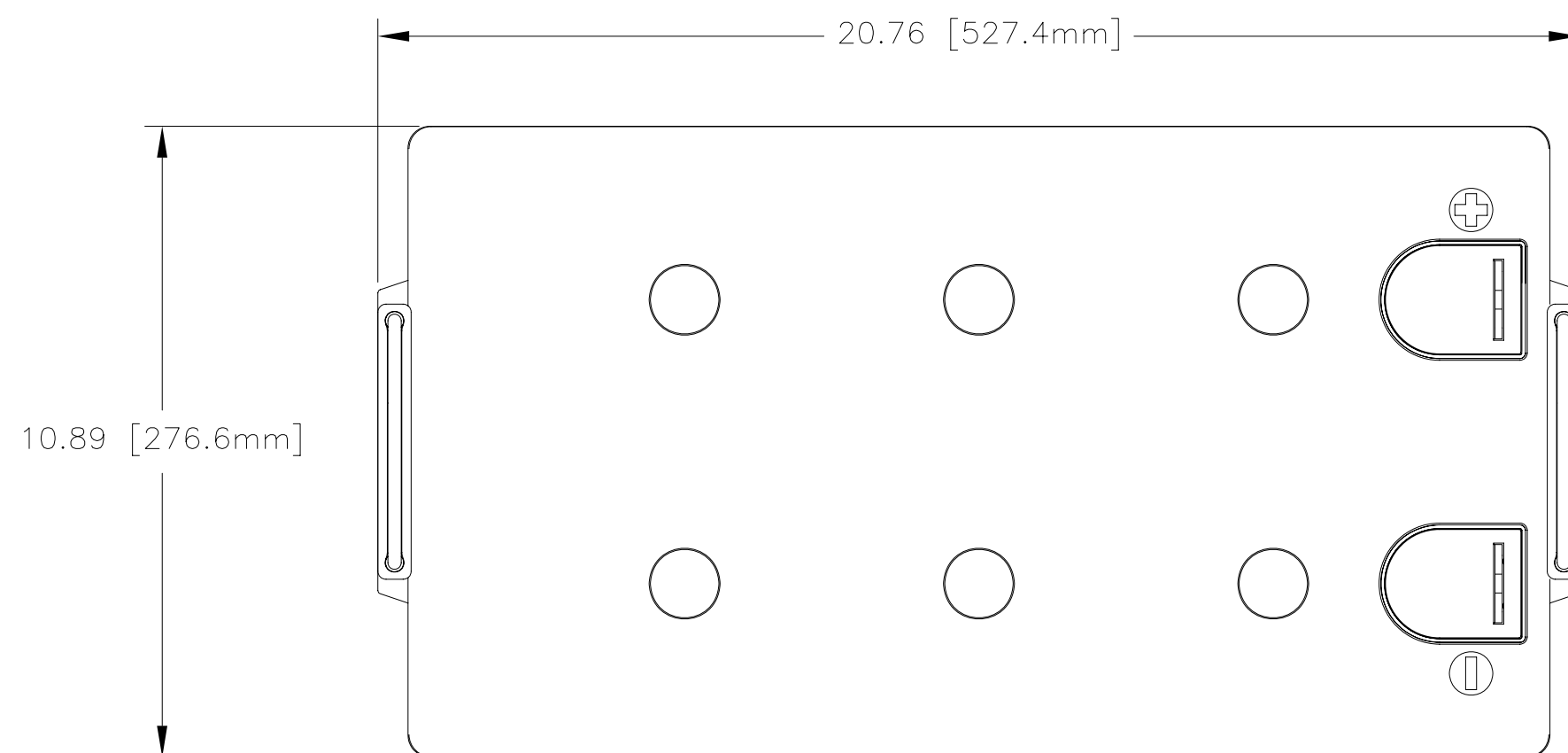

NOTE: SEE OPTIONS LISTED

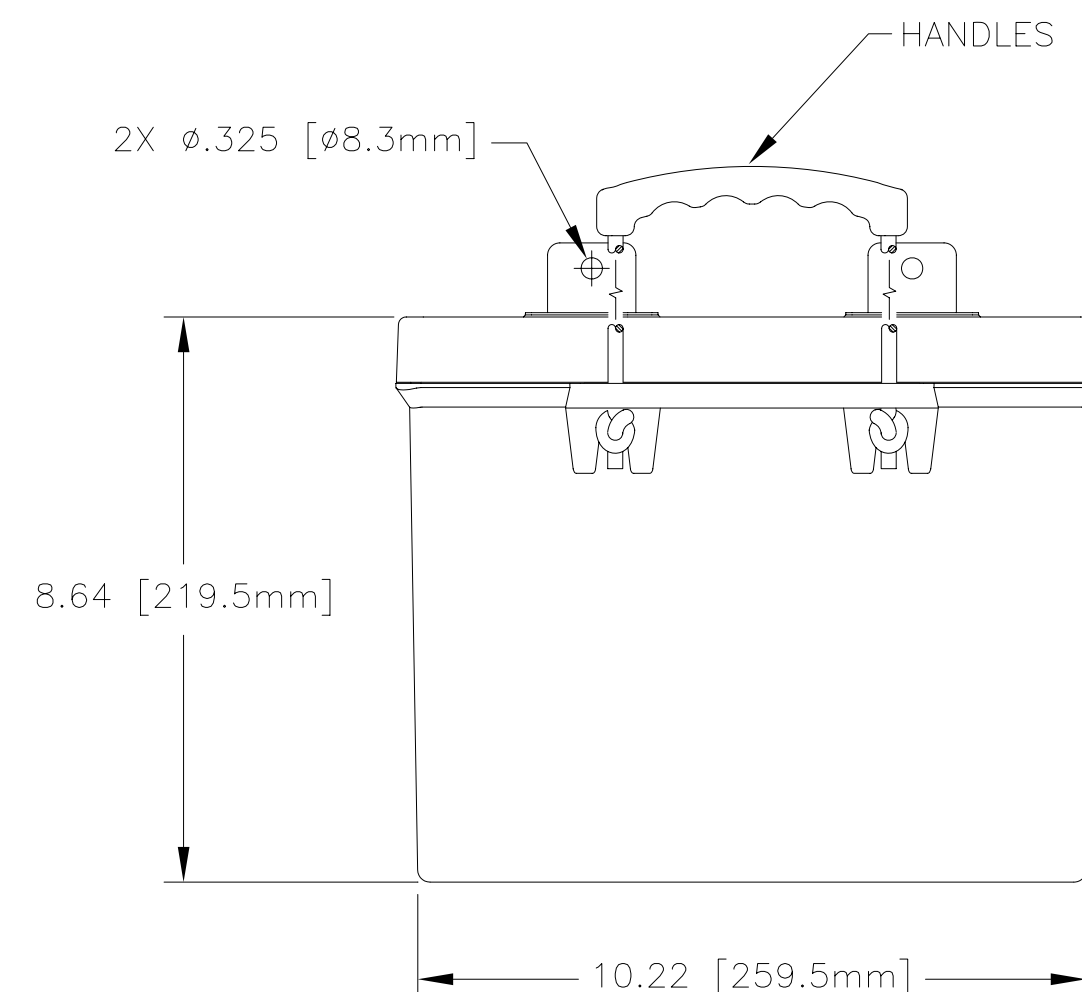
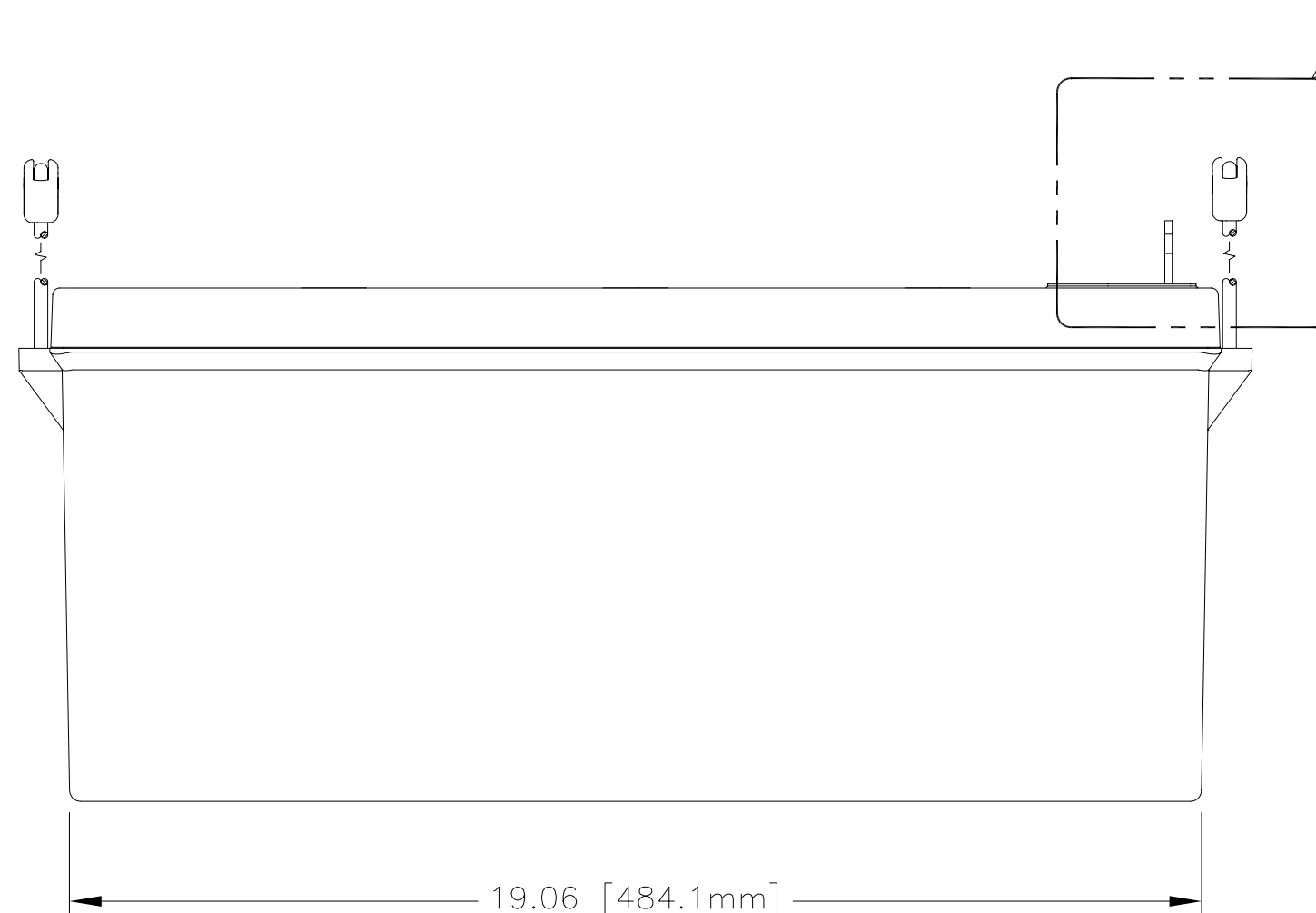

ENVELOPE DRAWING

CAPACITY RATINGS	
PART NUMBER	GPL-8D
NOMINAL WEIGHT	162 LBS[73.6 KG]
AMPERE HOUR CAPACITY @ 20 HOUR 1.75 VOLTS/CELL @ 77°F (25° C)	255 AH
MINUTES OF DISCHARGE @ 25 AMPS 1.75 VOLTS/CELL @ 77°F (25° C)	550 MIN

QTY REQD	CAGE CODE	PART OR IDENTIFYING NO.	NOMENCLATURE OR DESCRIPTION	MATERIAL SPECIFICATION	ITEM NO.
PARTS LIST					
UNLESS OTHERWISE SPECIFIED DIMENSIONS ARE IN INCHES TOLERANCES ARE:			CONCORDE BATTERY CORPORATION 2009 SAN BERNARDINO RD, W. COVINA, CA 91790		
FRACTIONS	DECIMALS	ANGLES	CONTRACT NO.	TITLE	
± 1/32	.XX ± .06	± 1°	NA	BATTERY, 12 VOLT, GPL-8D	
	.XXX ± .030		APPROVALS	DATE	
TREATMENT	NONE	CHECKED	TORRES J.	5/9/94	
FINISH	NONE	APPROVED	JR	5/9/94	
SIMILAR TO	ACT WT	CALC WT	ISSUED	JJ	10/22/09
NA	NA	NA			
SCALE NONE			SIZE C	CAGE CODE 63017	DWG NO. GPL-8D
				REV J	
				SHEET 1 OF 1	