

NOTES: UNLESS OTHERWISE SPECIFIED

1. SEE DRAWING NO. CB-00281 AND PROCEDURE P-1000 FOR ASSEMBLY AND TEST INSTRUCTION. PROCEDURES AND ASSEMBLY DRAWING ARE FOR INTERNAL USE ONLY.
2. ALL TESTING IS PERFORMED IAW BATTERY COUNCIL INTERNATIONAL STANDARDS.
3. ALL DIMENSIONS ARE IN INCHES [MM]
4. ABBREVIATION USED IN TITLE IS: SEALED LEAD ACID
5. TERMINAL HARDWARE KIT PROVIDED, PART NUMBER 6923

REVISIONS			
REV	DESCRIPTION	DATE	APPROVED
A	CHANGED HANDLE DIRECTION	2/26/07	JBT
B	CHANGED COVER & HANDLE, NOM. WT. 94 lbs WAS 85 lbs	11/6/07	JBT
C	REVISED TERMINAL DAMS, TERMINAL HEIGHT & HANDLES	9/16/09	JBT

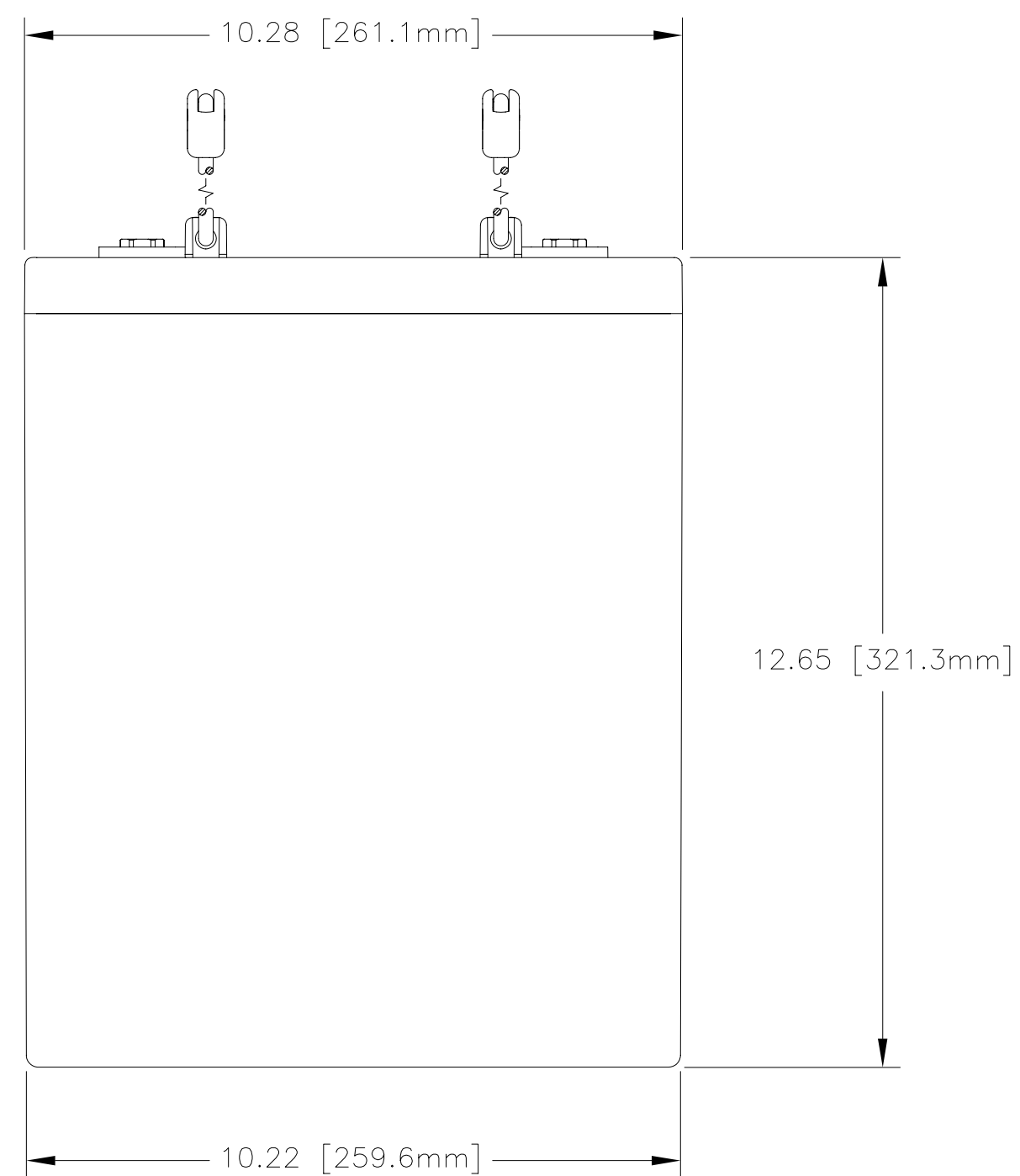
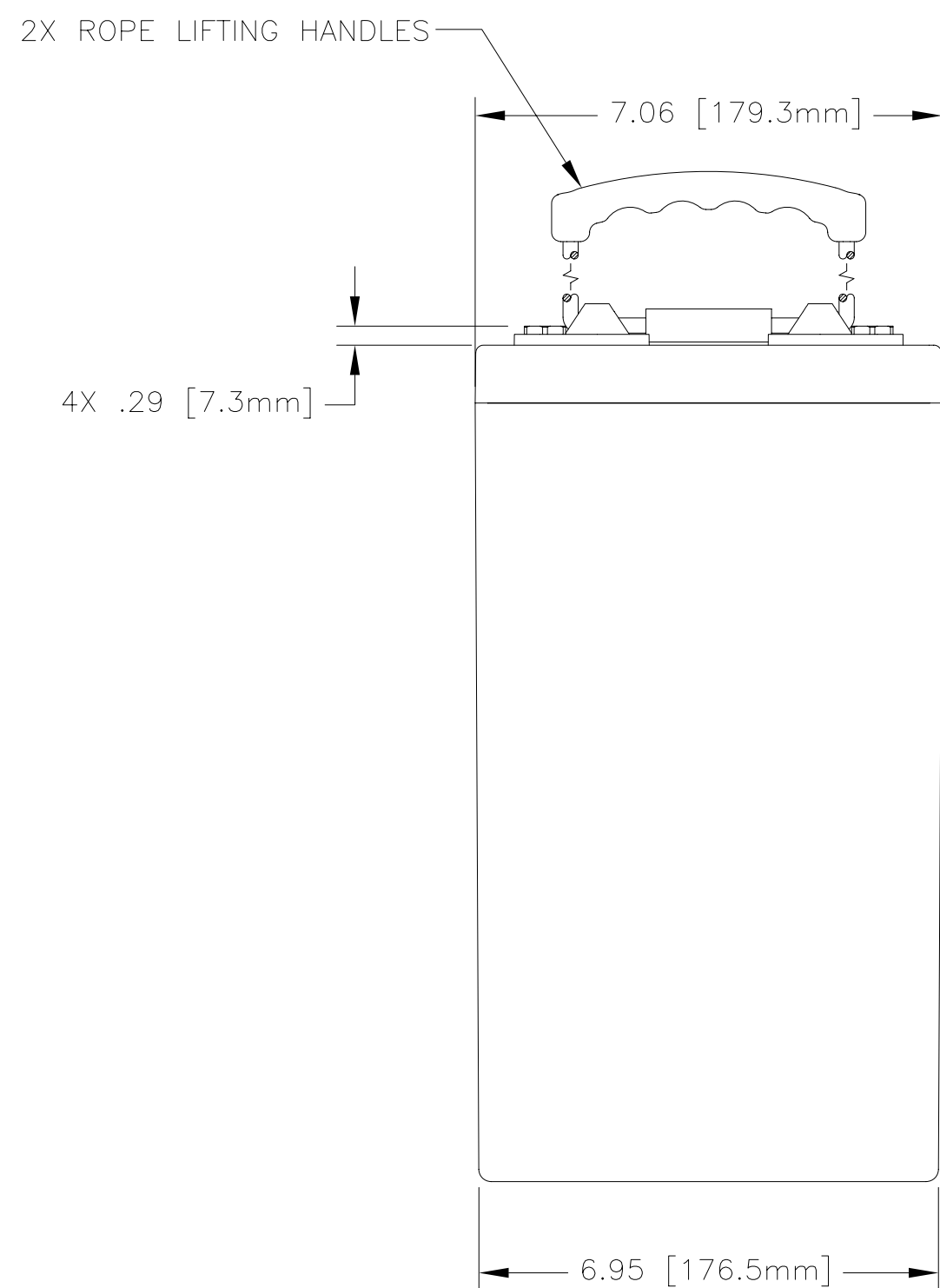
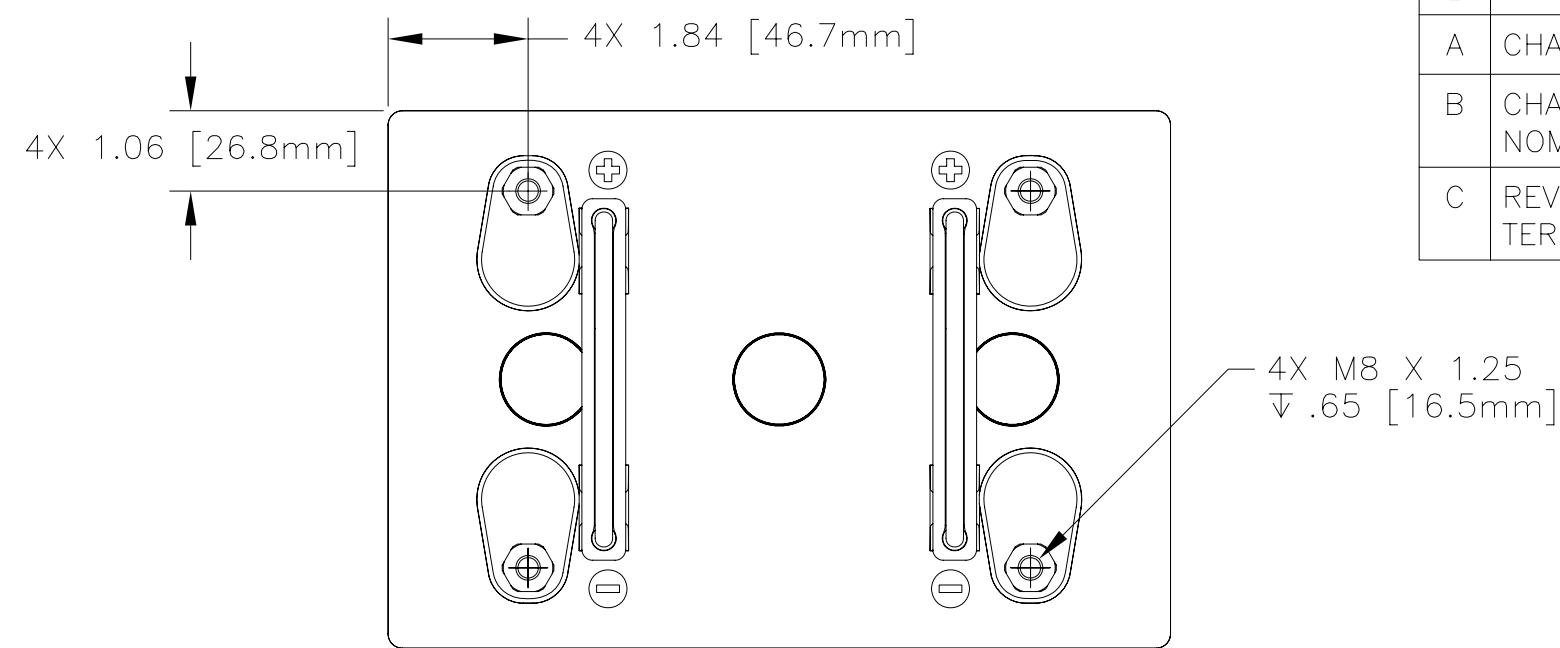

ENVELOPE DRAWING

QTY REQD	CAGE CODE	PART OR IDENTIFYING NO.	NOMENCLATURE OR DESCRIPTION	MATERIAL SPECIFICATION	ITEM NO.
PARTS LIST					
UNLESS OTHERWISE SPECIFIED DIMENSIONS ARE IN INCHES TOLERANCES ARE: FRACTIONS    DECIMALS    ANGLES ± 1/32    .XX    ± .12    ± 1° .xxx    ± .060			CONTRACT NO. APPROVALS    DATE DRAWN    D. AYALA    12/15/06		CONCORDE BATTERY CORPORATION 2009 SAN BERNARDINO RD, W. COVINA, CA 91790 TITLE BATTERY, SLA, 2 VOLT, PVX-9150T
TREATMENT    NONE		CHECKED    AMIII    1/5/07	SIZE    C	CAGE CODE    63017	
FINISH    NONE		APPROVED    JBT    1/8/07	DWG NO.    PVX-9150T	REV    C	
SIMILAR TO    N/A	ACT WT    N/A	CALC WT    N/A	ISSUED    JJ    9/18/09	SCALE    1=2.5	SHEET    1 OF 1

CAPACITY RATINGS	
PART NUMBER	PVX-9150T
NOMINAL WEIGHT	94 LBS [42.6 KG]
AMPERE HOUR CAPACITY @ 24 HOUR 1.75 VOLTS/CELL @ 77°F (25° C)	915 AH